

# Wechseleinsatz für u-tec System

insert for u-tec system

Größe UT 32

IK geeignet  
suitable for IC

size UT 32

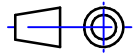

Darstellung symbolisch  
symbolical drawing

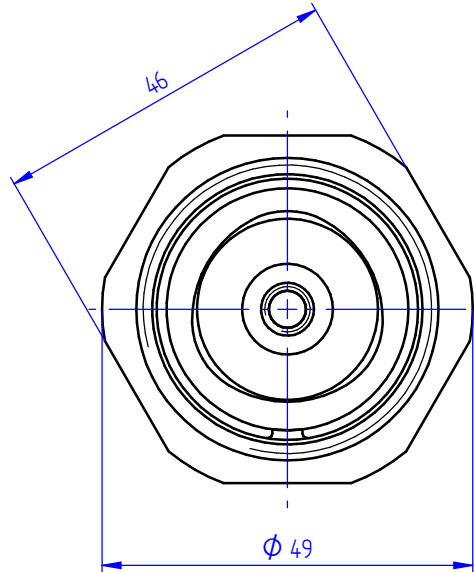
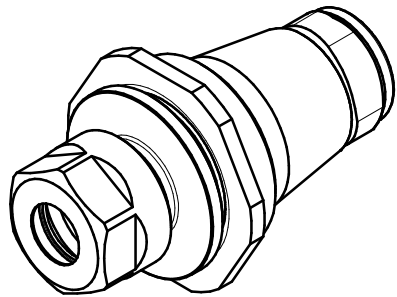

Optionen :  
options :



Dichtscheiben  
sealings



Spannzangen  
collets



Gewindebohrzangen  
tapping collets



Bedenschlüssel  
wrench

