

# Wechseleinsatz für u-tec System

insert for u-tec system

Größe UT 32  
size UT 32  
IK geeignet  
suitable for IC

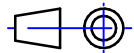

Darstellung symbolisch  
symbolical drawing

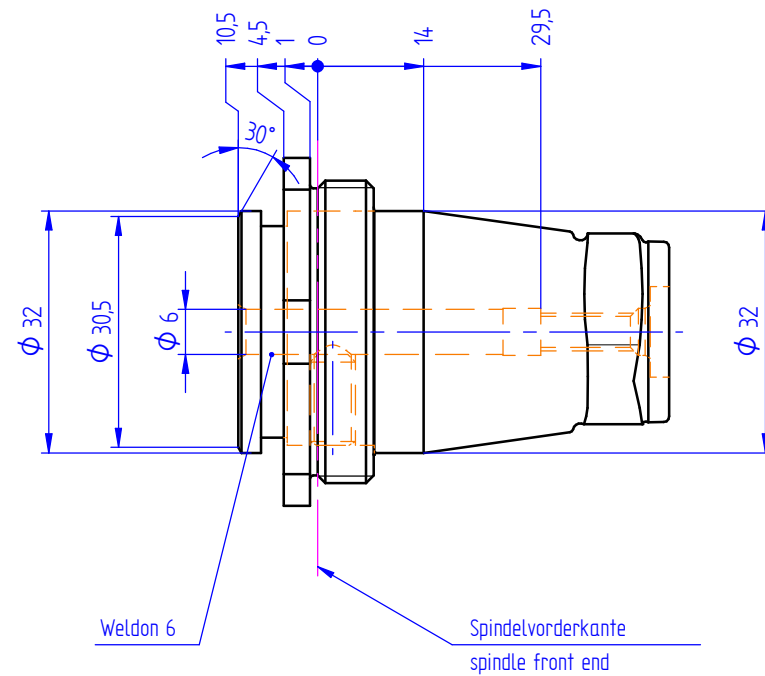
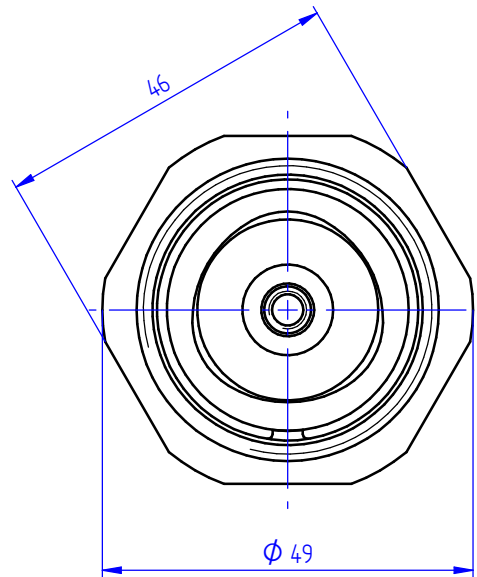
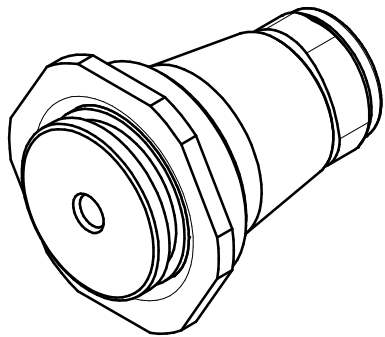

Optionen :  
options :



Bedienschlüssel  
wrench