

Wechseleinsatz für u-tec System

insert for u-tec system

Größe UT 25

IK geeignet
suitable for IC

size UT 25

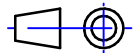

Darstellung symbolisch
symbolical drawing

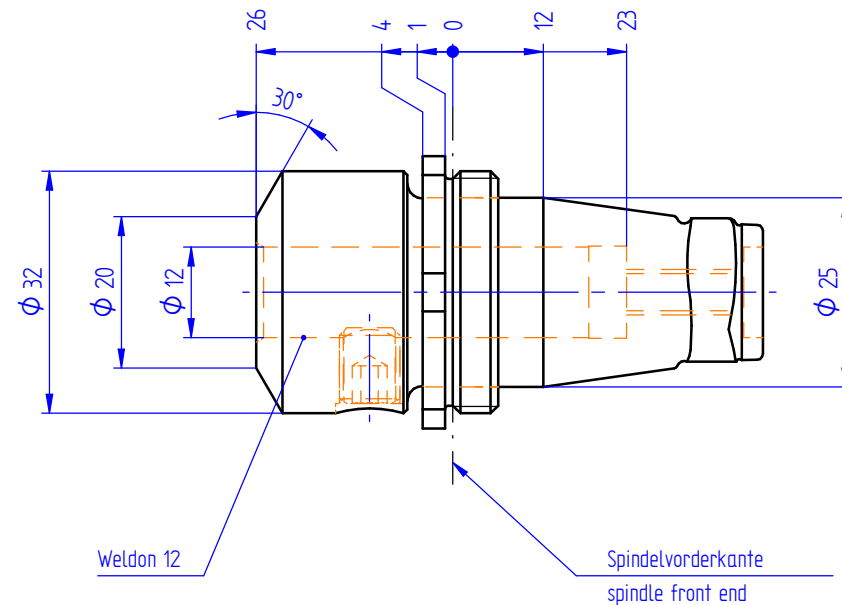
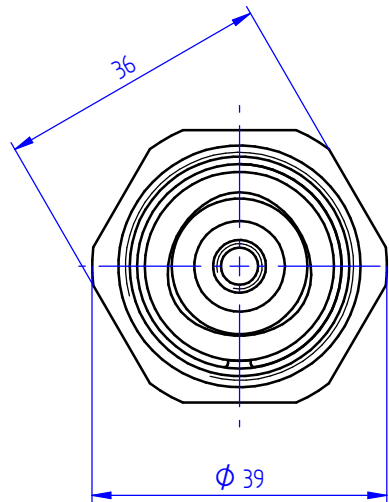
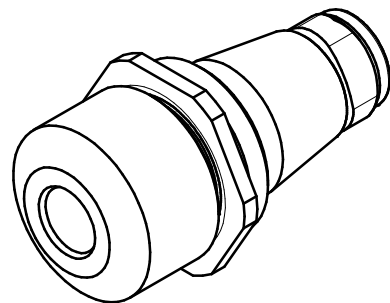

Optionen :
options :



Bedenschlüssel
wrench