

Winkel- Bohr- und Fräskopf

Radial drilling and milling head

bei externer Kühlmittelzufuhr Verschlusschraube durch Kühlrohr ersetzen
 using external coolant supply, please substitute locking screw by coolant tube

mit innerer Kühlmittelzufuhr für Hochdruck
 internal coolant supply (for high pressure)

mit kombinierter Kühlmittelzufuhr
 with combined coolant supply

p x n Diagramm D 00 010
 p x n diagram D 00 010



Darstellung symbolisch
 symbolical drawing

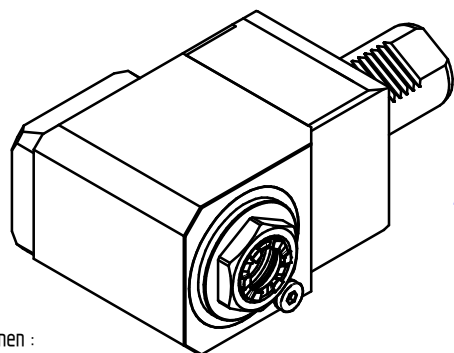

Optionen :
 options :



Dichtscheiben
 sealings



Spannzangen
 collets



Wechseleinsatz u-tec
 insert u-tec



Bedienschlüsselsatz
 set of wrench

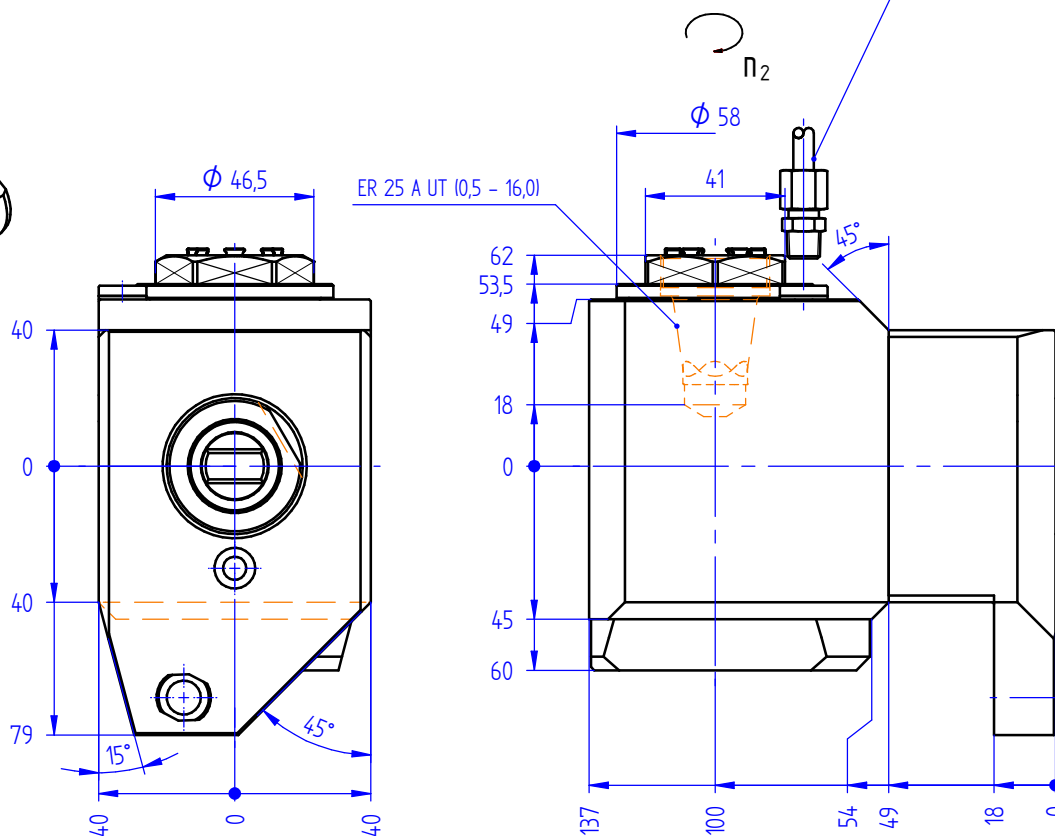

$n_2 = -n_1$



p max. [bar]	=	140
i	=	1:1
M ₂ max. [Nm]	=	50
n ₂ max. [min ⁻¹]	=	6000

» weitere Ausführungen auf Anfrage
 other models on request