

Axial-Bohr-und Fräskopf

Axial drilling and milling head

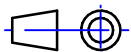

Darstellung symbolisch
symbolical drawing

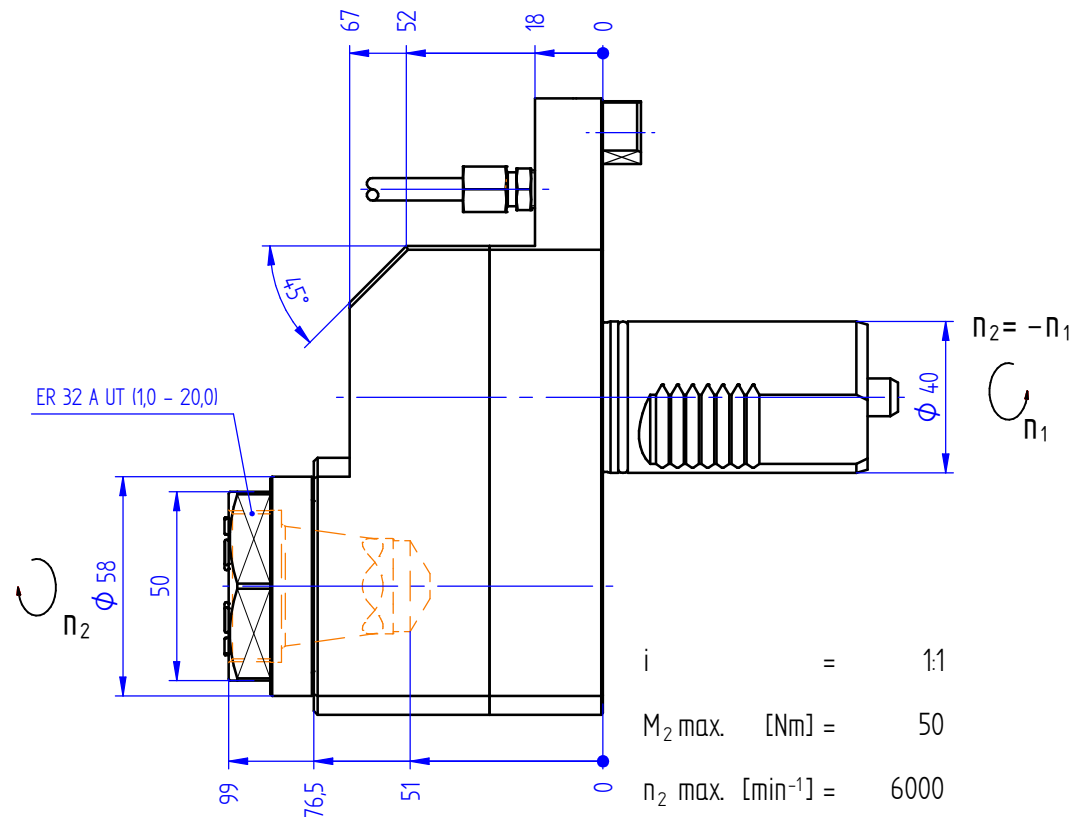
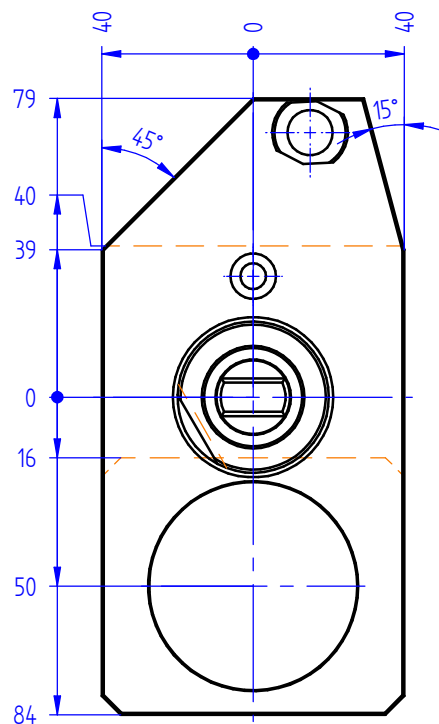
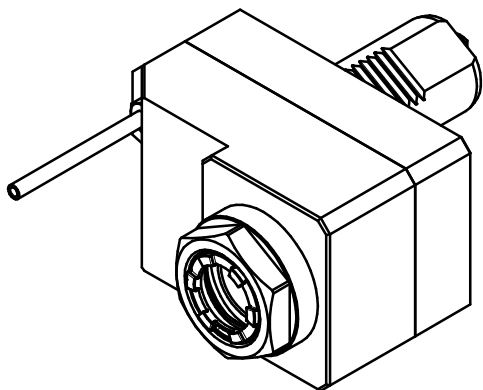

Optionen :
options :



Spannzangen
collets



Gewindebohrzangen
tapping collets



Wechseleinsatz u-tec
insert u-tec



Bedienschlüsselsatz
set of wrench

» weitere Ausführungen auf Anfrage
other models on request