

# Axial-Bohr- und Fräskopf

## Axial drilling and milling head

bei externer Kühlmittelzufuhr Verschlusschraube durch Kühlrohr ersetzen  
 using external coolant supply, please substitute locking screw by coolant tube

mit innerer Kühlmittelzufuhr für Hochdruck  
 internal coolant supply (for high pressure)

mit kombinierter Kühlmittelzufuhr  
 with combined coolant supply

p x n Diagramm D 00 010  
 p x n diagram D 00 010

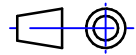

Darstellung symbolisch  
 symbolical drawing

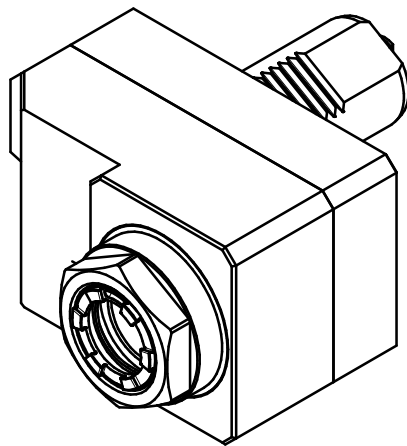

Optionen :  
 options :



Dichtscheiben  
 sealings



Spannzangen  
 collets



Wechseleinsatz u-tec  
 insert u-tec



Bedenschlüsselsatz  
 set of wrench

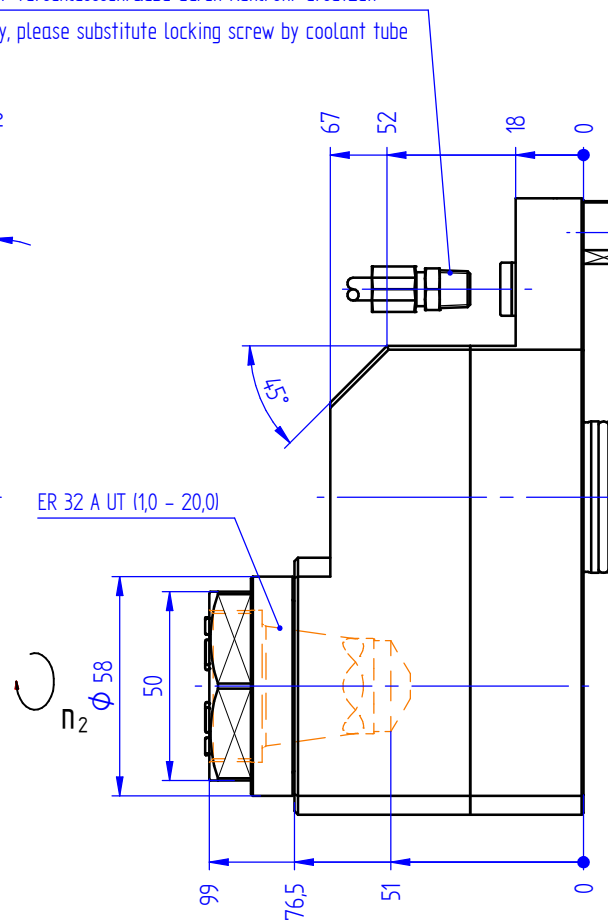
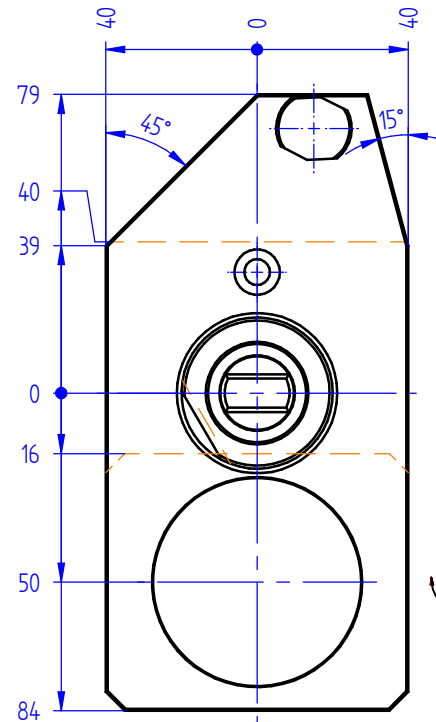

$$n_2 = -n_1$$



p max.	[bar]	=	140
i		=	1:1
M <sub>2</sub> max.	[Nm]	=	50
n <sub>2</sub> max.	[min <sup>-1</sup> ]	=	6000

» weitere Ausführungen auf Anfrage  
 other models on request