

# Axial-Bohr- und Fräskopf

Axial drilling and milling head

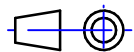

Darstellung symbolisch  
symbolical drawing

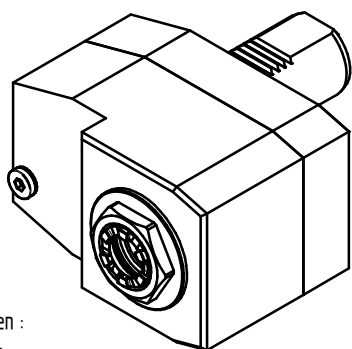

Optionen :  
options :



Dichtscheiben  
sealings



Spannzangen  
collets



Wechseleinsatz u-tec  
insert u-tec



Bedienschlüsselsatz  
set of wrench

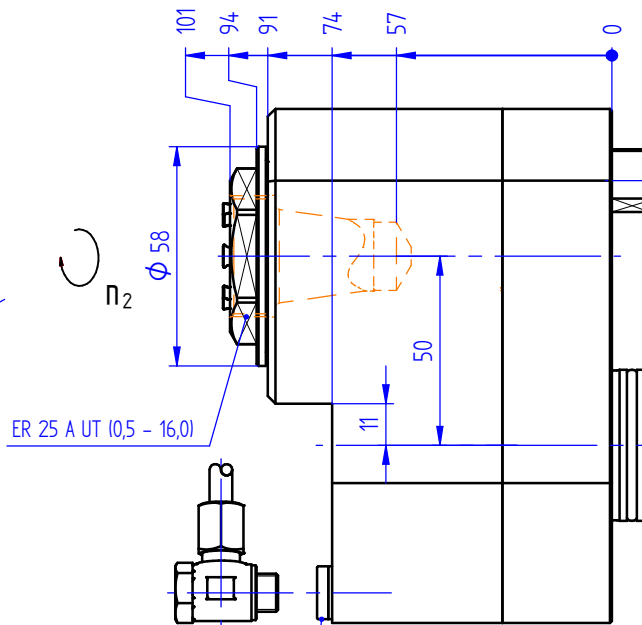
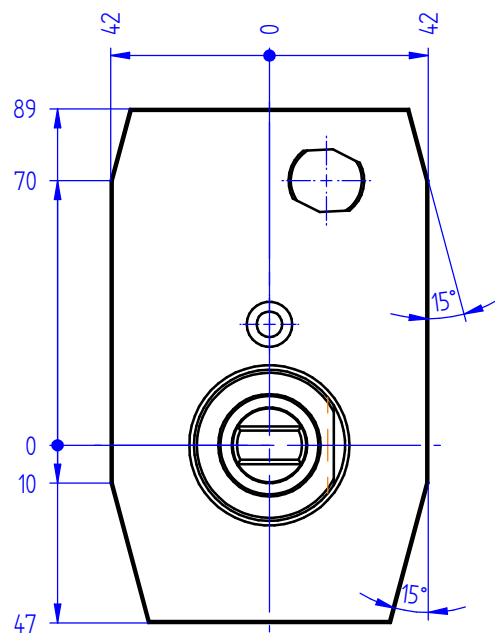

mit innerer Kühlmittelzufuhr für Hochdruck  
internal coolant supply (for high pressure)

mit kombinierter Kühlmittelzufuhr  
with combined coolant supply

p x n Diagramm D 00 010  
p x n diagram D 00 010

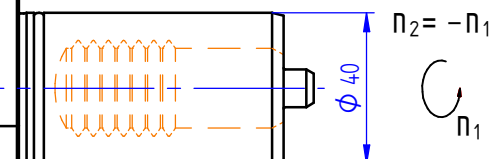

p max. [bar] = 140

i = 1:1

M<sub>2</sub> max. [Nm] = 50

n<sub>2</sub> max. [min<sup>-1</sup>] = 6000

bei externer Kühlmittelzufuhr Verschlusschraube durch Kühlrohr ersetzen  
using external coolant supply, please substitute locking screw by coolant tube

» weitere Ausführungen auf Anfrage  
other models on request